



MX

MEXICO

Diagram / Parts List

VC2512L

VACUUM CLEANER



(MX) VC2512L / VACUUM CLEANER

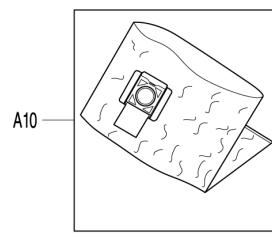
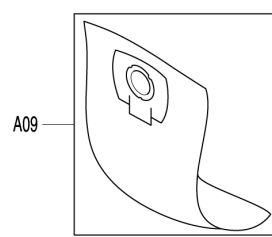
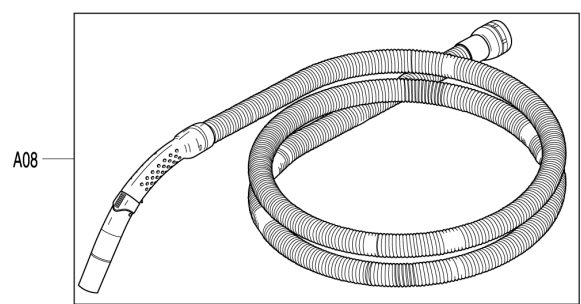
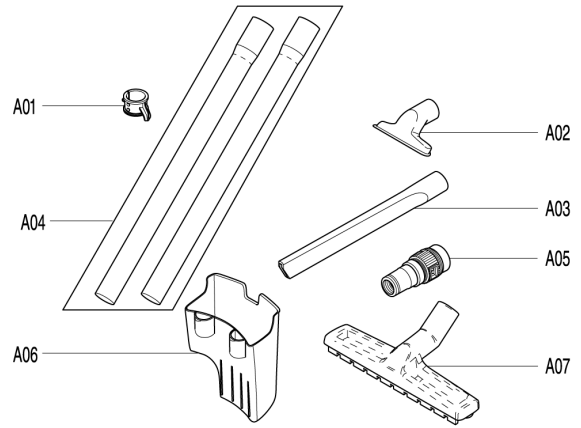
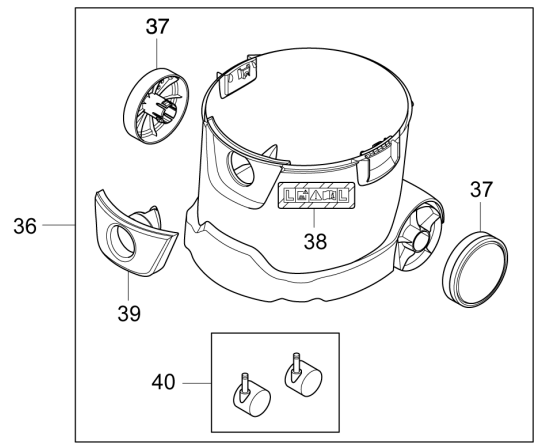
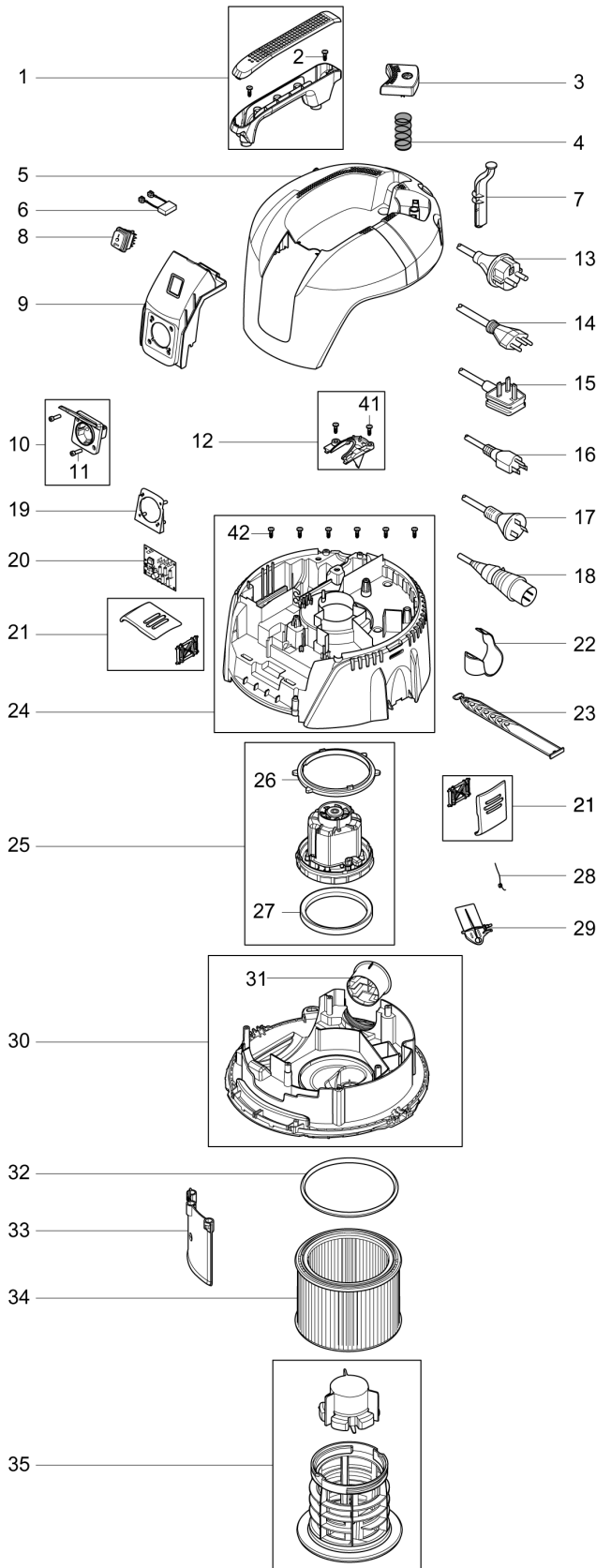

MX	MEXICO
-----------	---------------

VC2512L / VACUUM CLEANER

Item	Sub	Parts No.	Parts Description	Qty	I/C	E/C No.	Close No.	Remark
001		W107411598	HANDLE BLACK	1				
	D10		INC. 2					
002		W302003704	SCREW 5X18 TX20	2			Y08406	
002-1		W302004029	SCREW 5X18 TX20	2	O	Y08406		
003		W107409153	DEDUSTING KNOB BLACK	1				
004		W107411345	SPRING FOR DEDUSTING KNOB	1				
005		W107411996	COVER >MAKITA<	1				
006		W107404542	CAPACITOR 0.1 MICRO FARAD	1				
007		W107411600	KIT DEDUSTING ROD	1				
008		W107409135	SWITCH I-0-TOOL	1				
009		W107411997	INTERFACE >MAKITA<	1				
010		W302004338	SOCKET US.CA.MX -NEMA	1				
011		W302004032	SCREW 3,5X18 TX10	2				
012		W107409125	CABLE OUTLET	1				
016		W302004332	POWER CORD US,CA	1				
019		W302002052	PLUG SOCKET FIXING PLATE	1				
020		W107409189	ELEKTRONIC 110-120V	1				
021		W107409130	KIT LOCKING CLAMP	2				
022		W107402799	HOSE CLAMP	1				
023		W107409131	RUBBER STRAP	1				
024		W107409132	CLAMPING PLATE	1				
	D10		INC. 42					
025		W107409162	MOTOR 110-120V 1000 W	1				
	D10		INC. 26,27					
026		W107409163	UPPER MOTOR SEALING	1				
027		W107409164	LOWER MOTOR SEALING	1				
028		W909100083	TORSION SPRING	1				
029		W107409129	DEDUSTING FLAP	1				
030		W107409166	BASE PLATE WITH AIR OUTLET	1				
	D10		INC. 31					
031		W107409167	AIR OUTLET	1				
032		W107409165	SEALING FILTER	1				
033		W107409159	DEFLECTOR SHIELD	1				
034		P-70219	FILTER ELEMENT	1				
035		W107402646	KIT FILTER SUPPORT CAGE +FLOAT	1				
036		W107412001	CONTAINER 25L >MAKITA VC2512L<	1				
	D10		INC. 37-40					
037		W107409170	WHEEL D130	2				
038		W302004200	LABEL >DUST CLASS L<	1				
039		W107409169	INLET FITTING >VC2512L<	1				
040		W140642250	KIT CASTOR WHEELS 50MM	1				
041		W302003704	SCREW 5X18 TX20	2			Y08406	
041-1		W302004029	SCREW 5X18 TX20	2	O	Y08406		
042		W302003704	SCREW 5X18 TX20	6			Y08406	
042-1		W302004029	SCREW 5X18 TX20	6	O	Y08406		
A01		W107409979	TUBE HOLDER KIT	1				
A02		W142950000	NOZZLE UNIVERSAL	1				
A03		W295410000	CREVICE NOZZLE	1				
A04		P-72942	SUCTION TUBE 35X520MM 2PCS.	1				
A05		W107409977	TOOL ADAPTER WITH REGULATION	1				
A06		W107409980	TOOLBOX	1				
A07		W107402706	FLOOR NOZZLE 36X260MM	1				
A08		W107406115	SUCTION HOSE 32X3500MM	1			Y08126	
A08-1		P-81739	SUCTION HOSE D32X3500 W/TUBE	1	X	Y08126		
	C10	W107413340	HAND TUBE WITH REGULATION	1		Y08126		
A09		P-72899	FILTER BAG	1				
A10		P-70297	DISPOSAL BAG	1				
A11		W107418661	TOOL ADAPTOR 22 QUICK SET	1		Y07965		
A12		W107418680	TOOL ADAPTOR 38 VC2012-3011L	1		Y07965		

Interchange
O : Yes
X : No
< : the new part can be substituted for the current.
> : the current part can be substituted for the new.
S : Interchangeable as a set.